

# CREATING NEW DESIGN-BUILD-TEST EXPERIENCES AS OUTPUTS OF UNDERGRADUATE DESIGN-BUILD-TEST PROJECTS

John Paul Hermon

School of Mechanical and Aerospace Engineering, Queen's University Belfast

## ABSTRACT

This paper describes a methodology of using individual engineering undergraduate student projects as a means of effectively and efficiently developing new Design-Build-Test (DBT) learning experiences and challenges.

A key aspect of the rationale for this approach is that it benefits all parties. The student undertaking the individual project gets an authentic experience of producing a functional artefact, which has been the result of a design process that addresses conception, design, implementation and operation. The supervising faculty member benefits from live prototyping of new curriculum content and resources with a student who is at a similar level of knowledge and experience as the intended end users of the DBT outputs. The multiple students who ultimately undertake the DBT experiences / challenges benefit from the enhanced nature of a learning experience which has been "road tested" and optimised.

To demonstrate the methodology the paper will describe a case study example of an individual project completed in 2015. This resulted in a DBT design challenge with a theme of designing a catapult for throwing table tennis balls, the device being made from components laser cut from medium density fibreboard (MDF). Further three different modes of operation will be described which use the same resource materials but operate over different timescales and with different learning outcomes, from an icebreaker exercise focused on developing team dynamics through to full DBT where students get an opportunity to experience the full impact of their design decisions by competing against other students with a catapult they have designed and built themselves.

## KEYWORDS

Design-Build-Test, Project-Based-Learning

CDIO Standards: 5 (Design Implement Experiences), 7 (Integrated Learning Experiences), 8 (Active Learning)

## INTRODUCTION

The benefits of project based learning (PBL) have been evaluated in a number of studies. An international panel of evaluators of the Aalborg experiment in PBL, which began in 1974, found students were enthusiastic about this method of learning and that these students recognised their PBL experiences as the main source of professional skills developed during their degrees (Kjersdam, 1994). A later analysis (Kolmos 2010) further identified that compared to other Danish institutions Aalborg had the highest retention rates and one of the highest percentages of students finalising their studies on time. A meta-analysis of 43 PBL implementations (Dochy et al, 2003) found robust evidence supporting skills being developed by students and also found that despite some lower initial scores in technical knowledge assessments, there was significantly better retention of acquired knowledge in the longer term among PBL students. In a review of the research into active learning Prince (2004) found evidence to indicate PBL

develops students' abilities to solve open-ended problems and encourage an attitude of life-long learning. Prince also found that PBL frequently resulted in increased library textbook reading, improved class attendance and studying for meaning rather than simple recall. The rationale for CDIO Standard 5 (Design Implement Experiences) aligns with these findings and has been the inspiration for increasing the number of instances of such experiences within the degree programmes taught in the School of Mechanical and Aerospace Engineering at Queen's University Belfast (Hermon et al, 2010).

*CDIO Standard 5, Rationale:*

*Design-implement experiences are structured and sequenced to promote early success in engineering practice. Iteration of design-implement experiences and increasing levels of design complexity reinforce students' understanding of the product, process, and system development process. Design-implement experiences also provide a solid foundation upon which to build deeper conceptual understanding of disciplinary skills. The emphasis on building products and implementing processes in real-world contexts gives students opportunities to make connections between the technical content they are learning and their professional and career interests.*

Successful implementation of DBT experiences has however proved for many to be far from straight forward. Malmquist et al (2004) found in a review of DBT projects among the founding members of the CDIO Initiative that development was more complex than traditional courses and required appropriate new learning spaces to be effective. Additionally there tend to be additional costs incurred from the production of prototypes and functional artefacts in DBT projects that are not required in more traditional lecture style courses. As well as cost the throughput capacity of any prototyping or workshop facilities also becomes an issue if the DBT projects are to be used with larger cohorts. Among 7 key factors identified for effective implementation of DBT by Elger et al (2000) was an appealing topic that is amenable to simple prototype construction and a means to motivate students by using competition and/or public presentation. Setting a theme which students find attractive and which works well as a competition can however be a difficult task.

While the educational objectives and rationale expressed above are strongly held and while the desire to continually improve and extend the DBT content within the School's programmes exists there are also other demands on Faculty members time that make the development of new DBT exercises challenging, given these DBT exercises are more complicated and resource intensive than lecture based courses.

### ***Inspiration***

The inspiration for the methodology described herein was a paper presented at the Engineering and Product Design Engineering Conference (E&PDE 2013) at the Dublin Institute of Technology in September 2013. The work of Leutenecker et al (2013) relates to a mechatronics Design-Build-Test challenge at ETZ Zurich based on moving items up a scaled model version of a mountain with a device designed, built and operated by the students which attaches onto a cableway. The exercise described operated successfully with 550 participating undergraduate students of mechanical engineering and emphasised the differences between simple "funky" prototypes and more complex functional prototypes in meeting the educational objectives of the course. A key piece of equipment which enabled the rapid production of many fibre board prototype components was an industrial standard laser cutter. The large number of students involved and the fast turnaround of prototype components was of particular interest not only because of the growing number of students in the School of Mechanical and Aerospace Engineering (SMAE) at QUB but also because this conference coincided with the specification of equipment for a new Student Design Centre (FabLab style facility) within the

refurbished laboratory building in the School. The identification of a successful implementation in a comparative degree programme proved to be very timely indeed.

### ***Development of the Methodology***

The commissioning of the CadCam FB1800 laser cutter and the handover from the refurbishment contractors of School's new Student Design Centre was completed in October 2014; a few weeks into the start of the new academic year. There was therefore insufficient time to have a DBT project using this equipment ready and tested for that teaching period. Instead a proposal to run an individual student project with the new equipment was proposed. As this project would involve some paper based fact finding in the first few weeks the lack of immediate availability of the equipment could be accommodated within the project work plan. It was the initial definition of this 3rd year project (full year, 15 ECTS credits) and the requirement to meet the specific learning outcomes of the module that led the author to further develop the methodology described in this paper.

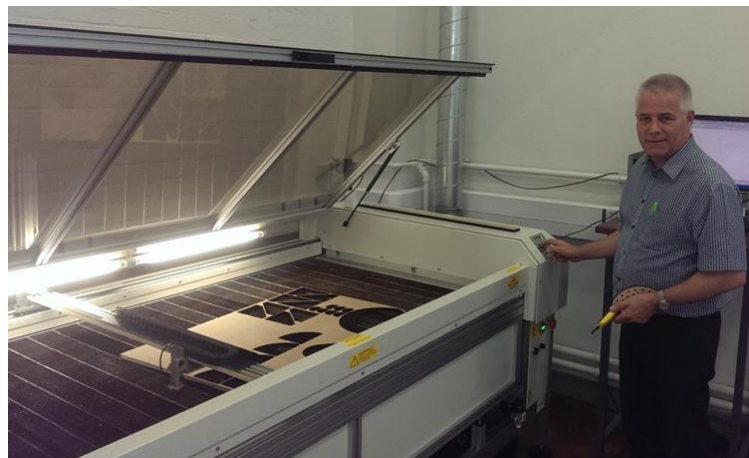

Figure 1 - CadCam FB1800 laser cutter in the QUB SMAE Student Design Centre

### ***Case Study - DBT Challenge Development (Table Tennis Ball Catapult)***

The description below is the original text from the project proposal. This was put into a pool of projects from which the students rank their preferences. Projects are allocated to individuals with the highest GPA students getting their selections considered first.

#### ***Aims:***

*Using the 'Innovation Process' Course at ETH Zurich as an example of what can be achieved with a cohort of 500+ students over the period of one semester, the objective of this project will be to develop and prove the viability (time and cost) of a new "Design for Manufacture" Design-Build-Test (DBT) challenge project for undergraduate students in the School of Mechanical and Aerospace Engineering. Since ETH Zurich makes effective use of a 2D laser cutter as the primary manufacturing tool for their project it is anticipated that this challenge will be based around the use of the School's new laser cutter (CadCam FB1800)*

#### ***Outline work plan:***

- *Literature review of existing student DFM project challenges*
- *Familiarisation with CDIO methodology*
- *DBT challenge theme ideation, selection and definition*
- *Realisation of functional prototype to meet the defined challenge brief*

- *Evaluation of time, cost and resource requirements for the context of a large cohort of students.*

*Project Deliverables:*

- *Define a “Design for Manufacture” Design-Build-Test challenge design brief.*
- *Quantify resource requirements for a range of cohort sizes to complete the challenge over 1 or 2 academic semesters.*

The individual projects in this module run over a full academic year, carry 15 ECTS credits with students expected to spend 300 hours working towards the project deliverables. The project in question was allocated to a 3rd year BEng Product Design Engineering (PDE) student. The student experience was essentially similar to that any other design project that would have run in this module but instead of the task being to design of a piece of test equipment for research or a widget of no future use the objective was to design an artefact that would be used as the basis of a design challenge for future teaching.

The underlying pedagogical theme of the project is one which actually is very attractive to the BEng PDE cohort in the School. A previous analysis of the destination of graduates from the programme (Hermon, 2013) identified that a significant minority (10%) of BEng graduates take a further year of study to gain a Postgraduate Certificate in Education (PGCE) and go on to become secondary level teachers of Technology and Design; an A-Level subject which the majority of applicants to the PDE programme possess. This therefore effectively utilizes what might otherwise be an underused resource of students who are inclined towards a teaching career. These students have a strong motivation to produce a good project in this subject area, since it will help them not only with their PGCE application but also with their future careers. This high percentage of BEng graduates pursuing a teaching career had been one of the more surprising results of the analysis of graduates, but one which helped identify their potential as developers of curricular content.

Over the 24 weeks of the Autumn and Spring semesters of 2014-15 the student project followed the outline work plan. During the weekly review meetings between student and supervisor it became apparent that the original emphasis on design for manufacture (DFM) could be extended to involve more design iterations. This was concluded since the initial measurements of cutting time for sample parts demonstrated that extremely fast turnaround of drawings to components could be achieved. It is worth noting at this point that the total cutting time for one set of components for the catapult device is under 20 minutes. While the focus of the challenge moved away from DFM and more to DBT the manufacturing tolerances and cutter compensation (required due to laser beam width) still needed to be considered when modelling the CAD components in the design phase (if operated in that mode).

The supervisor had a significant influence in the direction of project but with minimal time input of around 1 hour per week, mostly the review meetings. The student was the principal hands-on investigator. All of the design details and CAD modelling was done by the student, as was the production of drawings (DXF files mostly), the measurements of manufacturing tolerances, the assembly of components, the experimentation and alteration of parameters, iterative design modifications and liaison with the production manager. In total for a 15 ECTS credit module like this the expectation at QUB is that the student spends around 300 hours in total. While an experienced Faculty member might reach the same outcome faster than this there are some aspects such as the experimentation, testing and iterative changes which are necessarily time consuming and cannot be skipped.

One benefit to the student is that this type of active learning develops experimental and practical skills which are often absent on university entry.

One benefit to the supervisor is that the student is much closer to the target audience (in this case summer school / first year undergraduate / prospective undergraduates) in cognitive development and more able to provide valuable feedback on aspects such as the level of challenge or on the suitability, enjoyment and motivational aspects from a student perspective. Often an expert or senior academic forgets what it is like to not know something or to remember how some fundamental concept was learnt. In this respect the student had a major influence on the choice of theme. A catapult was chosen because the underlying mathematics on the trajectory of projectiles is part of the A-Level syllabi students entering the School will have studied previously. The application of mathematical modelling into DBT projects was another of the key success factors identified by Elger *et al* (2000) so the selection of a theme with a close link to fundamental mathematics opened up the possibility of getting students to justify design decisions on the basis of mathematical modelling. To assist with this an Excel spreadsheet (Figure 2) developed previously for an introductory course in the School was supplied to the students undertaking the design challenge mode.

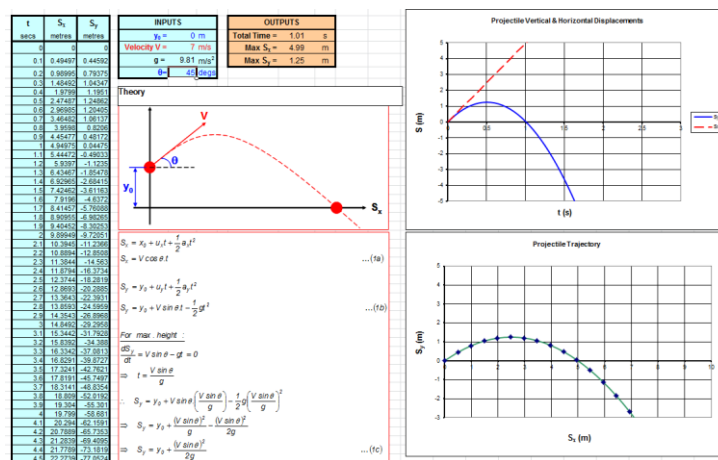

Figure 2. Excel spreadsheet for parabolic trajectory (credit CD McCartan)

### Operational Modes

Three modes of operation have been developed and tested which use the same catapult design and components. In all 3 modes of operation the objective of the competition is the same; to propel a standard table tennis ball a range of distances (not precisely known in advance) of between 1 and 5 metres into a bucket (Figure 3).

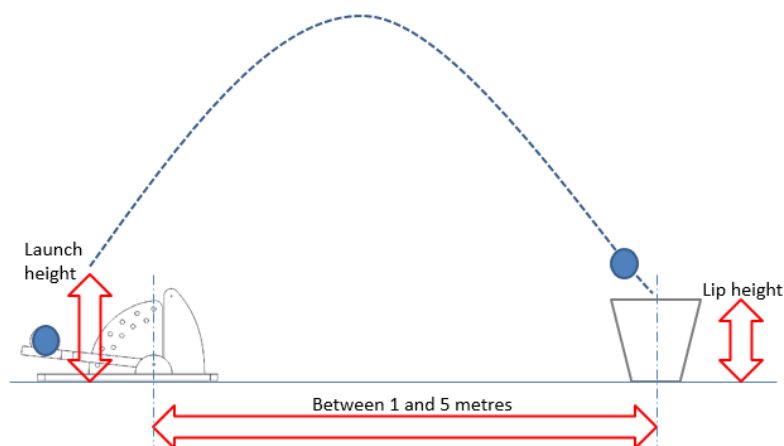

Figure 3. Table tennis ball catapult competition objective

### **Mode 1:**

#### **8x 3 hour sessions (summer school): Build-Test-Redesign-Build-Test-Compete**

Note - This mode presumes the students have previous CAD experience sufficient to be able to modify existing parametric 3D models and / or create new components and assemblies.

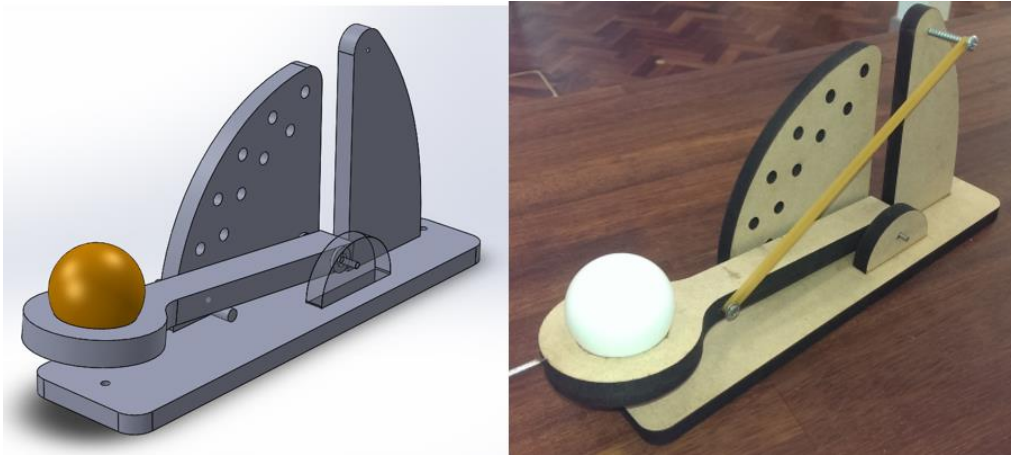

Figure 4. Mode 1 basic catapult (CAD model and MDF assembly)

In this mode the students get the full experience of designing their own device and then building this for a competition against their peers.

Initially the basic catapult is provided as a kit of parts. The students assemble and then proceed to test the device, characterising its performance for different launch angles and launch velocities. This is done by altering the number of elastic bands and the position of the pin which stops the arm rotating, hence launching the ball. The basic design however is deliberately flawed and when trying to throw the ball 5 metres can often break either about the pivot pin or where the arm strikes the stop pin. Some students like to immediately see how far they can throw a ball and quickly damage their device. In anticipation of this it is wise to make a few spare arms as replacements. The handover of these however can be delayed to simulate delivery time, as it would be in the real world. This also gives time and opportunity to discuss methodical test approaches with the students to improve their experimental practice. This aspect of this mode of operation was identified from a failed early iteration of the design. This highlights the benefit of having a sufficiently long test period to prove out the design, as is accommodated for in the undergraduate project schedule. A second design flaw in this initial design relates to the fact that the vertical sections are simply glued into slots in the base. The main quadrant with the holes that locate the stopping pin does over repeated testing tend to move up and out of the base. This provides another area of the device in which the students have scope to make and test their design improvements.

After a period of range finding and experimentation with the Excel file the students are made aware of the competition challenge and given a time schedule for design and manufacture of their components.

After all drawings have been submitted for manufacture the lecturer shares the details of an improved design (Figure 5) and runs a debrief session discussing the design rationale and the relationships to the mathematical theory. This provides the students with an example of how technical details of a design might be effectively communicated. They also receive instruction at this point on manufacturing tolerances and cutter offset compensation (due to laser beam width) that need to be taken into consideration when producing models and related DXF files for their designs.

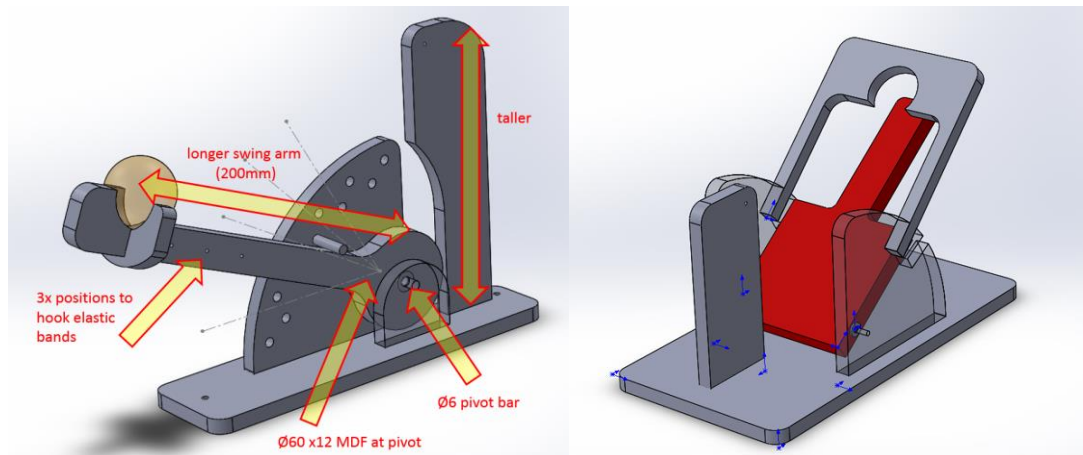

Figure 5. Mode 1 lecturer's improved catapult design (left) & summer school student design

After a scheduled break in the sessions (hours or days, depending on the cohort size) to allow all components to be manufactured the students next assemble their own designs and start experimental testing to characterise their own device. The sessions end with a competition which both keeps the students motivated to do well against their peers and also provides a nice climax to the sessions.

Optionally the students can be asked to make a short presentation explaining their design, the rationale for how it was developed, and reflection on how their device performed in the competition.

Mode 1 Learning Outcomes:

- Use of mathematical modelling to drive design decisions
- Use of DFM guidelines with respect to manufacturing tolerances
- Application of CAD skills
- Development of experimental practice and team working skills
- Development of communication skills (optional final presentation)

### **Mode 2:**

#### **2x 3 hour sessions (secondary school outreach): Build-Test-Compete**

This mode is intended to give prospective students an enjoyable experience with an introduction to the active learning approach used in a cdio-centric degree programme. The improved design shown in Figure 5 is provided in kit form for assembly by the students. This design is used because it is more robust and should not break if operated with the intended projectile range. The students assemble and test their device in the first 3 hour session with little instruction. The parts simply slot together and are fixed with wood glue. It is possible that these students might never have made anything so it is considered important to let them get hands on experience and then get to experiment with something to which they feel a sense of ownership. After lunch they are given a short presentation about experimental practice, and a brief introduction to manufacturing tolerances with respect to assembly fits, before being allowed some further time to perform more structured testing. The day ends with a competition, prize giving, photographs and a short debriefing session to highlight the active learning approach and the learning outcomes.

Mode 2 Learning Outcomes:

- Experience of basic component assembly
- Development of experimental practice and team working skills
- Introduction to engineering tolerances, limits and fits
- Awareness of cdio and active learning approach

### Mode 3:

#### 1x 3 hour session (team working icebreaker): Test-Compete

This shorter single session can be used as an icebreaker at the start of an undergraduate team project. The emphasis is on getting the students involved in something which requires co-operation. The students are provided with a pre-assembled catapult (improved design type) and given the competition objective information (Figure 3). They are then told to get started to test and characterise the device. After about 30 minutes, of usually aimless and unorganised “play”, the lecturer(s) who have been observing the students attempts call a halt and give a presentation about experimental best practice (Figure 6), and advised on appropriate roles for team members.

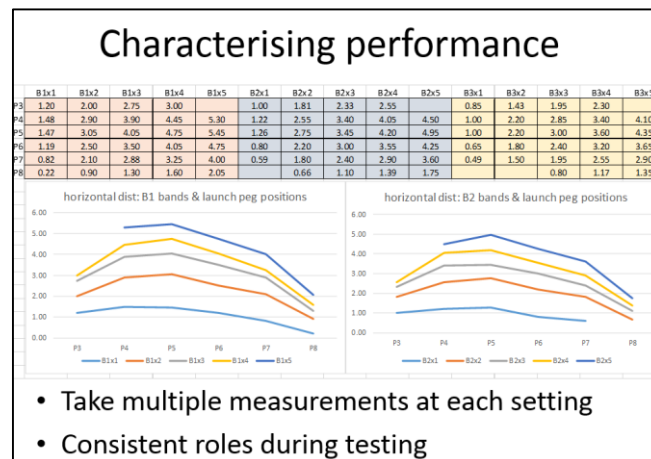

Figure 6. Slide from presentation on experimental best practice

The students then have about 90 minutes to conduct a more structured investigation before the session finishes with the usual competition.

Mode 3 Learning Outcomes:

- Development of experimental practice and team working skills

#### Examples of Operational Modes

The 3 modes have been operated successfully on live student groups. The longer format Mode 1 with a group of 28 Chinese summer school students as one of 4 accelerated modules studied over a 4 week period in August 2015. The shortest icebreaker session (Mode 3) with a cohort of 82 year 3 MEng Mechanical and Product Design Engineering students in week 1 of their major year-long group DBT project in September 2015. The Mode 2 outreach version was used with a group of 38 “high flying” secondary school students as part of an initiative to attract more of these high caliber students into engineering subjects at degree level, also in September 2015.

Anecdotal evidence and feedback sheets gathered at these events were overwhelmingly positive but no formal evaluation was done as part of this paper.

#### Current Projects in Progress

In academic year 2015-16 the author is currently supervising 2 new projects using the same methodology with the objective of generating new equipment and DBT design challenges:

1. Design and build a test device to explore the parameters influencing the flight of table tennis balls, particularly how spin affects trajectory.
2. Design of an undergraduate Design-Build-Test experience which integrates engineering science from the stage 1 modules in the School of Mechanical and Aerospace Engineering.



In both cases the laser cutter is again the “workhorse” for manufacturing components but both projects are also seeking to extend the links to other modules in the curriculum by including elements of fluid mechanics, machine elements such as bearings and gears, electric motors and control systems.

## CONCLUSIONS

The case study described herein demonstrates that student projects can produce outputs that are suitable for use as teaching resources in DBT design challenges and experiences. Effective use was made of a previously untapped resource of BEng Product Design Engineering students, with an interest in following a teaching career, as developers of curriculum content appropriate to their peers.

## REFERENCES

- Dochy, F.; Segers, M.; Van den Bossche, P.; Gijbels, D. (2003); Effects of problem-based learning: a meta-analysis; *Learning and Instruction* 13; 533–568
- Elger, D.F.; Beyerlein, S.W.; Budwig, R.S. (2000); Using Design, Build and Test Projects to Teach Engineering; 30th ASEE/IEEE Frontiers in Education Conference; 18-21 October 2000, Kansas City, MO
- Hermon, P.; McCartan, C.; Cunningham, G. (2010); Group Design-Build-Test Projects as the Core of an Integrated Curriculum in Product Design and Development; *Engineering Education: Journal of the Higher Education Academy Engineering Subject Centre*, Vol. 5 (2), 2010, p. 50-58
- Hermon, P (2013) The efficacy of a CDIO based integrated curriculum as preparation for professional practice in product design and development; *Proceedings of the International Conference on Engineering and Product Design Education (E&PDE13, 5-6 Sept 2013) Dublin, Ireland*
- Kjersdam, F. (1994) Tomorrow's Engineering Education - The Aalborg Experiment; *European Journal of Engineering Education*; 19:2; 197-204
- Kolmos, A.; (2010) Premises for Changing to PBL; *International Journal for the Scholarship of Teaching and Learning*; Vol. 4, No. 1
- Leutenecker, B.; Lohmeyer, Q.; Meboldt, M. (2013): Impart 'Design for Production' Knowledge by Application of Functional Prototyping; *Proceedings of the International Conference on Engineering and Product Design Education (E&PDE13, 5-6 Sept 2013) Dublin, Ireland.*
- Malmqvist, J.; Young, P.W.; Hallstrom, S; Kuttenekeuler, J; Svensson, T.; (2004) Lessons Learned from Design-Build-Test-Based Project Courses; *Proceedings of the International Design Conference (Design 2004, May 18-21) Dubrovnik, Croatia*
- Prince, M. (2004) Does Active Learning Work? A Review of the Research; *Journal of Engineering Education*, 93(3), 223-231

## Acknowledgements

Tamsin Sturgeon (Stage3 BEng PDE 2014-15) was the student who undertook the project from which the catapult DBT experiences were derived.

Raymond Finney (Student Design Centre Manager) was responsible for manufacturing all of the components used both during the development of the DBT exercises and during their operation with various groups of students.

The hard work and perseverance of both of these individuals has contributed to the development of a valuable resource.

## BIOGRAPHICAL INFORMATION

**J Paul Hermon**, is a Senior Lecturer (Education) in the School of Mechanical and Aerospace Engineering at Queen's University Belfast, is Programme Director for the Product Design Engineering degrees and Co-Chair of the CDIO UK & Ireland region.

### ***Corresponding author***

J Paul Hermon  
Queen's University Belfast,  
Ashby Building,  
Stranmillis Road  
Belfast BT9 5HN  
[p.hermon@qub.ac.uk](mailto:p.hermon@qub.ac.uk)



This work is licensed under a [Creative Commons Attribution-NonCommercial-NoDerivs 3.0 Unported License](https://creativecommons.org/licenses/by-nc-nd/3.0/).